

--

Date:
Client:
Project:

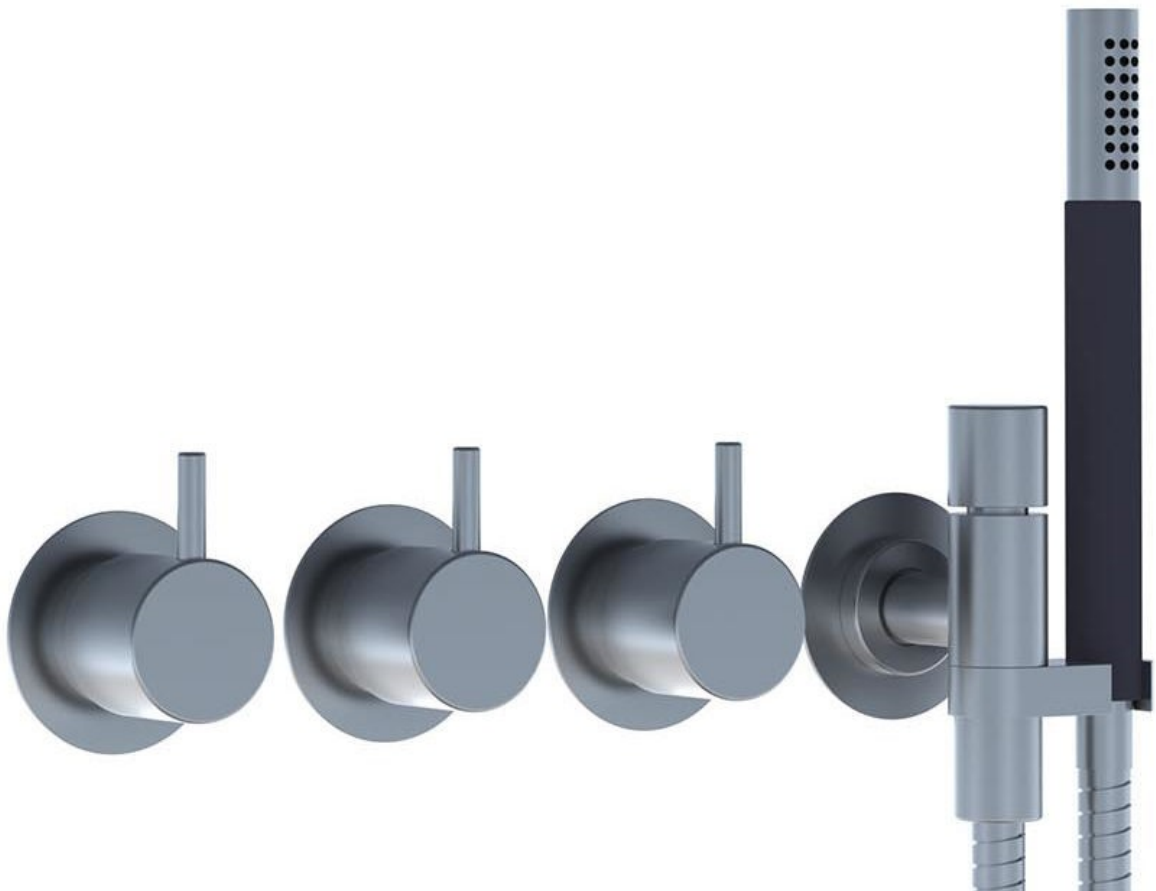

**871R-081D**

Two-handle build-in mixer with ¼ turn ceramic disc technology and diverter.

871R-081DUP = Mixer 800N.

871R-081DAP = 2 pcs. handles NR17, handle NR19G, hand shower and hand shower holder with non-return valve 070R, hose 1500 mm, double head shower 080D, 60 mm circular flange 001, 3 pcs. 001G.

**Flow**

	Bar:	1.0	2.0	3.0	4.0	5.0
070R <sup>1)</sup>	(l/min)	5.2	7.3	9.0	9.0	9.0
080D <sup>2)</sup>	(l/min)	14.4	20.4	25.0	28.9	32.3

<sup>1)</sup> USA: Flow restricted to 1.8 gpm (7.0 l/min)

<sup>2)</sup> USA: Flow restricted to 1.8 gpm (7.0 l/min)

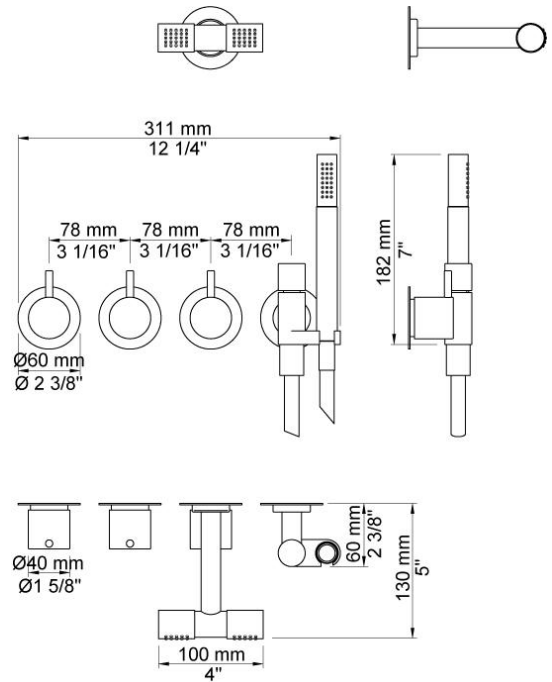

**Available in colors**

Color 16, Polished chrome	Color 62, Deep black
Color 20, Brushed chrome	Color 63, Copper
Color 28, Matt white	Color 64, Brushed Copper
Color 40, Brushed stainless steel	Color 65, Gold
Color 60, Black	Color 68, Silver
Color 61, Brushed black	Color 70, Brushed Gold

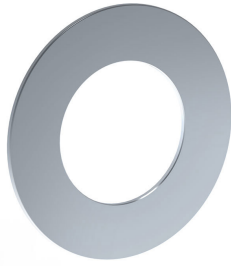

**001**  
60 mm circular flange.  
Hole Ø30 mm.



**001G**  
60 mm circular flange. Hole Ø33 mm.

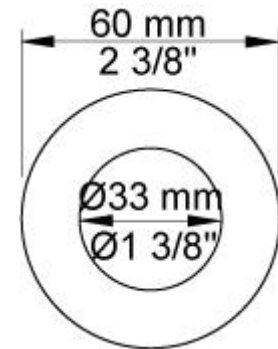

**070R**  
Hand shower, hand shower with holder to the right and hose with non-return valve.

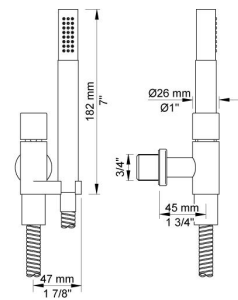



**080D**  
130 mm double head shower.  
60 mm cover flange included.

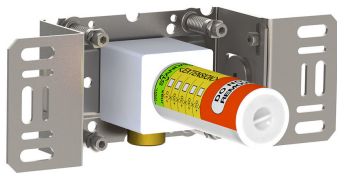
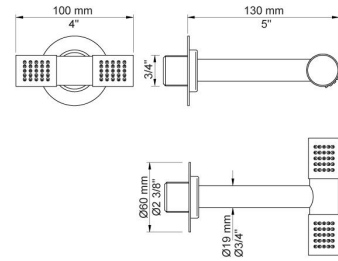

**200M**  
Separate outlet socket.  
½" connection to copper, steel, iron or pex pipe work.

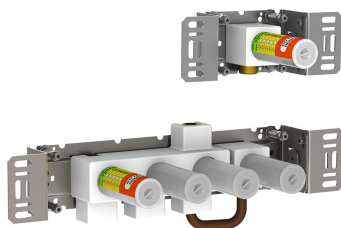
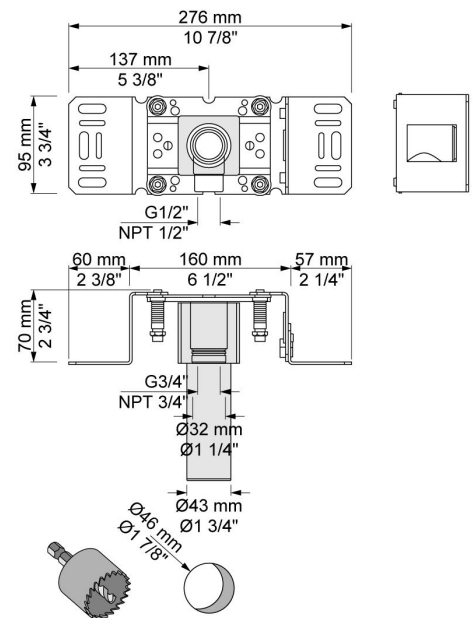

**800N**  
Two-handle build-in mixer with diverter, including one fixed and one separate outlet socket, 200M.  
½" connection to copper, steel, iron or pex pipe work.

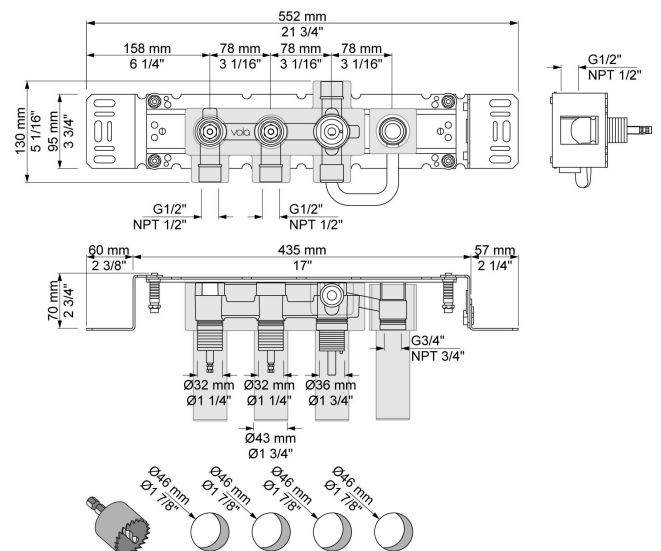



**NR17**

Operating handle for 600, 700, 800, 900, 1500, 2800, 2900, S20, S21, S40, S42 incl. variants. Ø40 mm.

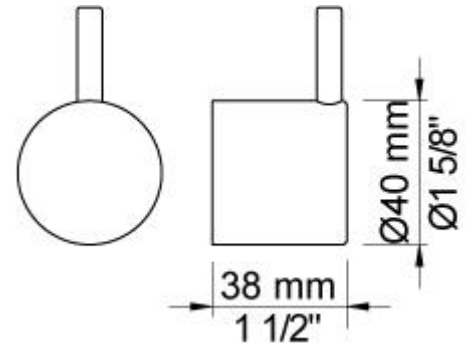

**NR19G**

Diverter handle for 400 and 800 incl. variants. Ø40 mm. With peg in the same colour as handle (standard).

